

# Little GIANT<sup>®</sup>

## Pump Company

### 1-MA SERIES



#### Features

- Epoxy coated die-cast aluminum housing
- Oil-filled motor
- 7' maximum lift
- 70 watts
- 1/4" MNPT Discharge
- Thermal overload protection on 521500 and 521286
- For submersible use only

#### Construction

- Motor — 1/200 HP Oil Filled
- Intermittent Liquid Temp up to — 120° F
- Intake — N/A
- Discharge — 1/4" MNPT
- Housing — Epoxy coated cast aluminum
- Cover — Epoxy coated cast aluminum
- Volute — Polypropylene
- Impeller — Polypropylene
- Shaft Seal — Nitrile
- Screen — Polypropylene

Small submersible oil-filled pump with epoxy coated cast aluminum housing. For commercial, industrial and home applications including statuary fountains, water displays, air conditioners, machine tool coolants, and many other applications where liquid must be transferred or recirculated. This compact 170 GPH pump features a 1/4" MNPT discharge, 7' shut-off head capability, and screened inlet.

# Little Giant Pump Co.

## 1-MA SERIES

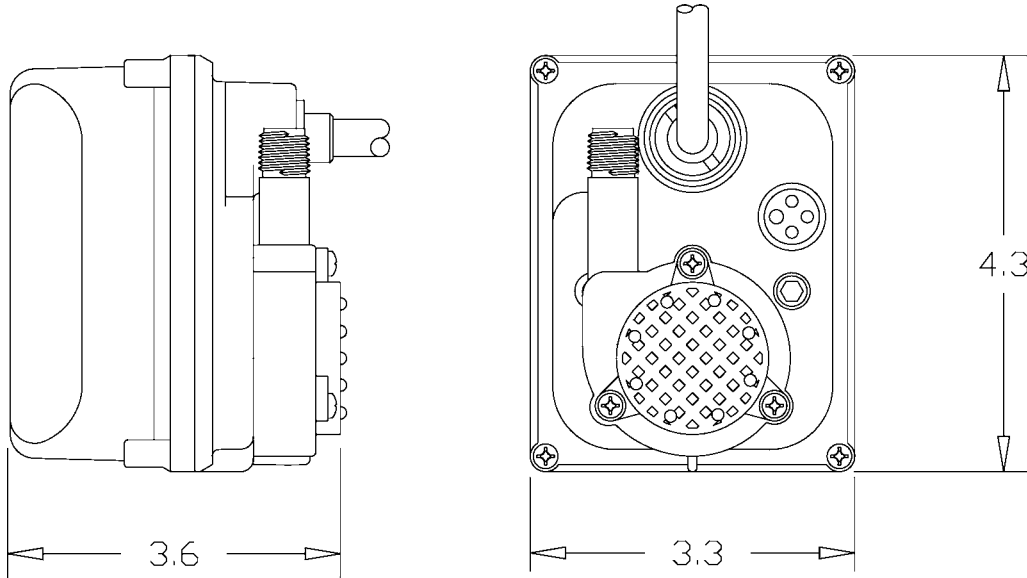

### Specifications

Model No.	Item No.	Discharge Size	Listing(s)	HP	Volts	Hertz	Amps	Watts	Performance (GPH @ Head)			Shut Off		Pwr. Cord (ft)	Weight (Lbs.)
									1'	3'	5'	Feet	PSI		
1-MA	521203	1/4" MNPT	UL	1/200	115	60	1.1	70	170	140	100	7	3.0	6	3.17
1-MA	521500	1/4" MNPT		1/200	127	60	1.1	70	170	140	100	7	3.0	6	3.17
1-MAT	521286	1/4" MNPT	UL/CSA	1/200	115	60	1.1	70	170	140	100	7	3.0	10	3.33

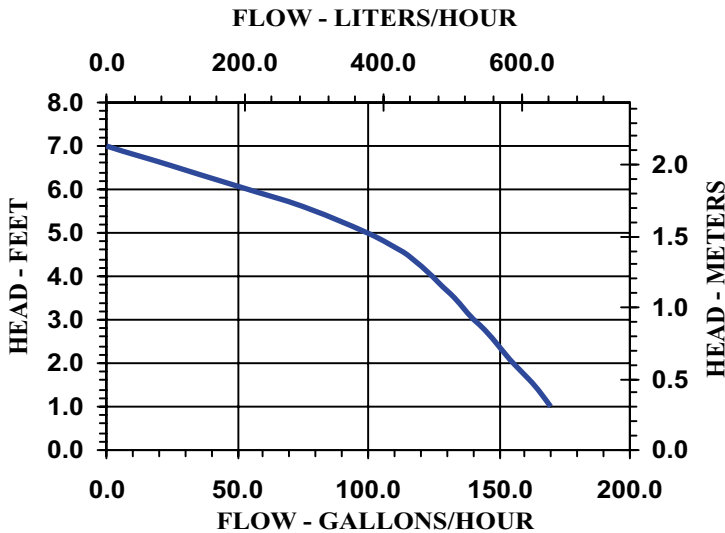

### Replacement Parts

Volute	101350
Impeller	101441
Screen	122903

**Little Giant Pump Co.**  
 PO Box 12010  
 Okla. City, OK 73157  
 Phone: 405.947.2511  
 Fax: 405.228.1550  
[www.LittleGiantPump.com](http://www.LittleGiantPump.com)